

Whirlwind





POWERFUL. DURABLE. PURE VACUUM SWEEPER

The Elgin® Whirlwind1® has continuously raised the bar in truck mounted vacuum sweeping performance in the North American market. Combining a proven low maintenance design with an extra-wide sweeping path and short wheelbase. Whirlwind1 with single-engine technology reduces daily maintenance, increases productivity, and enhances the operator experience while offering performance flexibility; allowing the selection of single or dual nozzle, and 28 in (711 mm) or 36in (914 mm) side brooms for a maximum sweep path of 12 ft (3658 mm). Choice of conventional or cab over chassis. From the unique extending nozzle to the overall robust construction, Whirlwind1 street sweepers will continue leading the market.

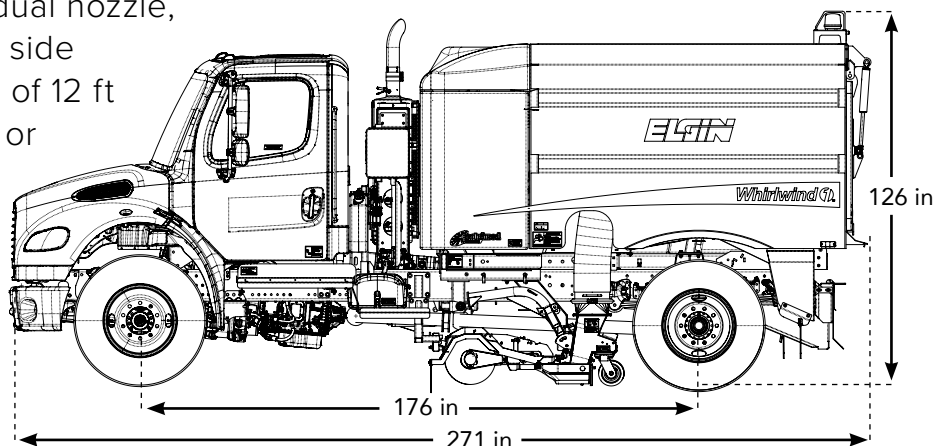

VARIABLE SPEED DEVICE (VSD)

The VSD replaces the diesel auxiliary engine, eliminates a complex aftertreatment system, and untimely regenerations. It's simple to operate, and carries a three year warranty.



SCAN to view our VSD animation
OR visit elginsweeper.com

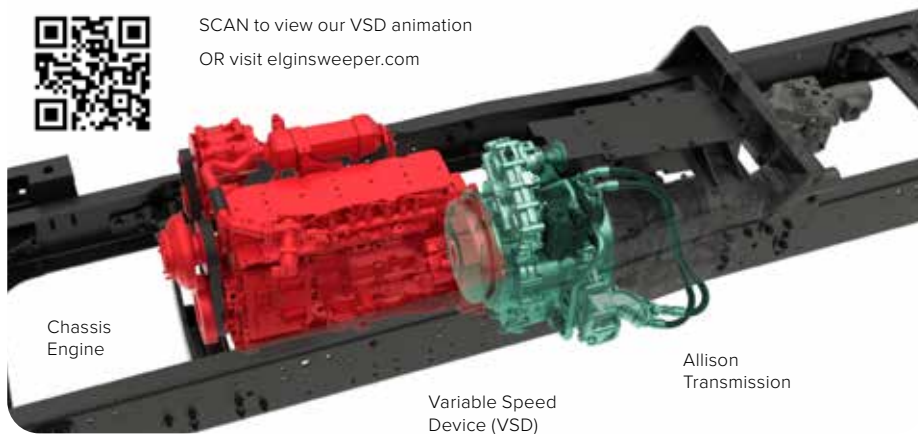

Chassis Engine

Variable Speed Device (VSD)

Allison Transmission

Singular Push-Button Technology

The Whirlwind1 does not require engaging the park brake before shifting into work or road modes. Shift-on-the-fly design provides unmatched ease of operation; combined with increased productivity.

The VSD replaces the diesel auxiliary engine, eliminates a complex aftertreatment system, and untimely regenerations. It's simple to operate, and carries a three year warranty.

SINGULAR PUSH-BUTTON TECHNOLOGY

The Whirlwind1 does not require engaging the park brake before shifting into work or road modes. Shift-on-the-fly design provides unmatched ease of operation; combined with increased productivity.

ROAD MODE:

When the VSD is in road mode, the chassis operates normally. The accelerator pedal controls the chassis engine speed and the transmission shifts normally.

WORK MODE:

When the VSD is in work mode, the chassis accelerator now controls only the input speed to the transmission, not the chassis engine speed.



CHASSIS - MODE SELECT	
CHASSIS MODE	INDICATOR LIGHT
ROAD	OFF
WORK	ON
ACTIV. FAULT	FLASHING

INNOVATIONS **AT WORK**

The Elgin Whirlwind1 is specially suited for uneven, patched roads and jobs involving dirt, sand, millings, general street sweeping, leaves and road debris applications. The Whirlwind1 is also recognized as a proven and powerful tool for maintenance and restoration of permeable pavement.



Flexible Design

The Whirlwind1 mounts on a conventional or cab-over chassis, respectively offering maneuverability, visibility, ease of entry and egress. Elgin's standard auto pickup-in-reverse feature protects the sweep components while allowing quick change of sweeping locations.

High Productivity Suction Nozzle(s)

A single or dual 32 in (813 mm) abrasion-resistant suction nozzles are available. Each nozzle covers 174 in² (1123 cm²) and extends 15 in (381 mm) beyond the tire's track for increased performance closer to the curb. The 11 in (279 mm) diameter suction hose accepts large debris. The suction nozzle rides on two heavy-duty pivoting caster wheels allowing it to track, staying in the path of the debris and following road contours. The suction nozzles are equipped with a front-mounted shutter that allows easy entry of larger/bulky objects and large quantities of leaves.

Memory Sweep

Elgin's exclusive Memory Sweep feature allows the operator to resume ALL previous sweeper settings with one-touch control to increase productivity. The feature provides a multi-screen display for tilt angle, broom hours, water level, and diagnostic information.

Ergonomic Controls

The Whirlwind1's centrally-mounted console features rocker switches for all sweep functions and complete gauges (fuel level, fan hour meter, fan RPM) for quick review of system conditions. A backup camera and alarm are standard for increased operational awareness and safety.

BUILT TO LAST

High Capacity/Efficient Loading

The 8 cubic yard (6 m³) capacity hopper provides extended sweeping time. Abrasion-resistant steel inlet deflector directs debris flow to the center of the hopper for maximum capacity utilization. Drop down hopper screens make the Whirlwind1 easy to clean.



Unique Trailing Arm Side Brooms

Elgin's trailing arm design provides inward motion to avoid obstacles. Standard parallelogram linkage allows side brooms to closely follow road contours, and maintain a consistent broom tilt (angle) with the road surface. Digging pressure is adjustable in-cab. Brooms can be extended outward for maximum sweep path.



Superior Dust Suppression

The durable 335 gal (1268 L) polyethylene dual water tanks provide ample water capacity. Water is delivered using two run-dry water pumps; distributed through quick-to-clean water nozzles. High/low in-cab selectable pump speeds allow adjustment by application.



Simple, Easy-Access Maintenance

The Whirlwind1 is designed so that systems are accessible and easy to service. The hydraulic system with o-ring face seal (ORFS) fittings is designed for long life and leak-free operation. Heavy-duty, waterproof electrical connectors, and color-coded wires are functionally stamped for quick identification and trouble shooting.

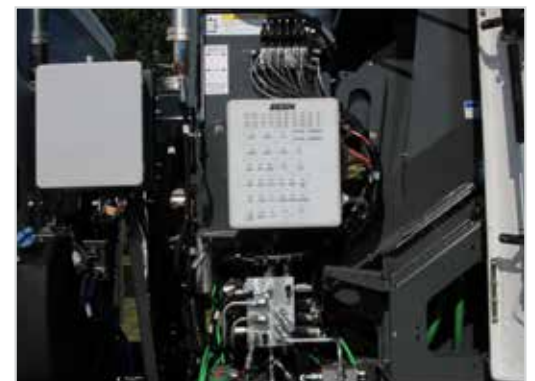



POWERFUL CLEANING SYSTEM

The Whirlwind1 single-engine provides a simple solution; a single push-button operation. This procedure incorporates a Variable Speed Device (VSD) – a planetary gearbox – located between the chassis engine and the Allison transmission. The VSD has two modes of operation; road mode and work mode.



EFFICIENT AIR CONVEYANCE SYSTEM

Efficient air flow, including a superior vacuum source and air routing path, is at the heart of the Whirlwind1.

- High volume air flow at high velocity results in exceptional one-pass pickup while eliminating plugging that can occur in similar type sweepers.
- A hydrostatically driven nine-vane closed face turbine fan provides maximum airflow



HIGH-PRODUCTIVITY SWEEP SYSTEM

The Whirlwind1's versatile sweep path picks up debris close to the curb and across the widest expanse of road in its class.

- The sweep system includes one or two suction nozzles, trailing arm side brooms, and a centrally-mounted extension broom.
- You can choose 28 in (711 mm) or 36 in (914 mm) diameter trailing arm side brooms that can be operated individually or simultaneously for a sweep path of up to 144 in (3658 mm)*.
- Choose between single or dual 32 in (813 mm) welded-steel suction nozzles that can be operated individually or simultaneously.
- The 11 in (279 mm) diameter suction hose accepts large debris. Quick disconnect allows an operator to inspect and clean the hose intake without raising the hopper.

ENHANCEMENTS



Lifeliner® hopper system

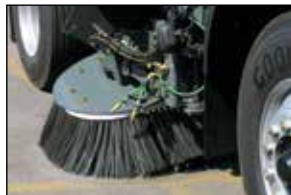

In-cab side broom tilt and extended reach



Wandering hose

ADDITIONAL ENHANCEMENTS

- Automatic lubrication system
- Broom camera system (rear standard)
- PM-10 dust suppression
- Broom hour meter
- Front spray bar
- And more



OUR COMMITMENT TO QUALITY ONLY BEGINS WITH OUR EQUIPMENT

The Elgin Whirlwind 1 is manufactured in an ISO 9001 certified, advanced industrial plant. We employ the latest technology to build the most reliable equipment, including high-precision laser cutters, efficient, accurate computer numerical controls (CNC), and a sophisticated powder coating system.

When you build a quality product you can back it up with a full one-year, unlimited hours warranty. Elgin also backs up your investment with superior local service and support. Our goal is to keep your machine—and your entire operation—up and running.

The Whirlwind 1 can be customized to your unique requirements to meet local standards and regulations by means of a broad selection of configurations, options and accessories.

Through our international dealer network, we maintain a vast inventory of spare parts and offer fast shipment to any region of the world.

Altogether, the rugged, reliable Elgin Whirlwind 1 is easy to operate, easy to maintain, and an easy choice when you are looking for quality equipment that is built to last.



Whirlwind 1 Truck Mounted Vacuum Sweeper Specifications

Chassis Engine*	Electrical System	Side Brooms	Pick-up Nozzle	Hopper
<p>Make Cummins ISB 6.7 or equivalent</p> <p>Type In-Line 6 cylinder, turbocharged diesel</p> <p>Displacement 409 cubic inch (6.7 L)</p> <p>Horsepower 200 (150 KW) @ 2,400 RPM</p> <p>Torque 520 ft-lbs (708 Nm) @ 1,600 RPM</p> <p>Fuel Tank Capacity 50 gal (189 L)</p>	<p>Chassis Battery Rating 12 volt</p> <p>Sweeper Battery Rating 1000CCA</p> <p>Chassis Engine Alternator 160 amperes</p> <p>Lights Side broom, rear clearance, rear identification</p> <p>Reversing Safety Electric back-up alarm, sweep components raise automatically</p>	<p>Diameter 28 in (711 mm) WB</p> <p>Chassis Specific 36 in (914 mm) WB</p> <p>Chassis Specific</p> <p>Disc Construction Steel plate</p> <p>Speed Constant</p> <p>Drive Hydraulic motor, protected by relief valve</p>	<p>Width: 32 in (812 mm)</p> <p>Area: 174 in² (1119 cm²)</p> <p>Suction Hose: 11 in (280 mm)</p>	<p>Volumetric Capacity 8 cubic yard (6 m³)</p> <p>Effective Dump Angle 50°</p> <p>Hopper Screens Hinged, quick release, steel</p> <p>Lifting Double acting Hydraulic</p> <p>Hopper Dump Door Hydraulic open/close and lock/unlock</p>

Whirlwind

POWERFUL. DURABLE. PURE VACUUM SWEEPER

Searching for a solution that eliminates maintaining and servicing an auxiliary engine on a vacuum sweeper? Elgin® Sweeper Company has the answer. The Whirlwind1 eliminates all things associated with a diesel auxiliary engine, providing value to customers that extends beyond having one less engine. Elgin Sweeper single-engine technology has undergone years of customer focused testing and validation; ensuring a design that exceeds expectations!

WHY WHIRLWIND 1?

- Proven single-engine technology with shift-on-the-fly operation
- Customer tailored performance configurations
- Application flexibility
- Standard simultaneous sweep/dual nozzle sweep functionality
- Suction nozzle(s) designed for demanding road surfaces
- Dual-engine platform with patented SharedPower technology available



Elgin Sweeper • 1300 West Bartlett Road, Illinois 60120 USA
Phone 847-741-5370 | Parts & Service 877-800-1111

Specifications subject to change without notice. Some products shown with optional equipment. Elgin® is a registered trademarks of Elgin Sweeper. Products may be covered by one or more United States Patents and/or pending patent applications. Elgin Sweeper is a subsidiary of Federal Signal Corp. | Federal Signal Corp. is listed in the NYSE by the symbol FSS.